

MaxX TG

New

Hand controlled magnetic lifters for thin gage ferrous loads

The easiest, safest and most efficient way to handle low thickness sheets and tubes



POWERFULL - STRONG - COMPACT



**SAFETY
FACTOR 3**

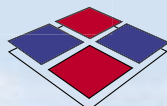

TECNOMAGNETE®

Safety through Power

Maxx tg the evolution of the species

The special design of the polar surface together with a proper balancing of the magnetic masses located in the stator and in the rotor, has enabled to achieve an optimal concentration and distribution of the magnetic strength all over the contact area of the load, and thus allowing an easier rotation of the handle whilst keeping the characteristics of safety and reliability of all the maxx lifters unchanged.

- solid block construction
- high power rare heart permanent magnets
- special treatment on all surfaces for corrosion and wear protection

pipe lifting



unit lifting from stack



special poles configuration



skimming from 4 mm

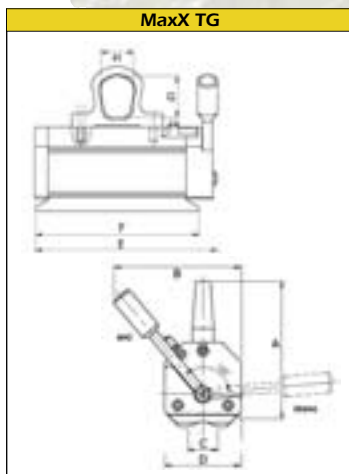
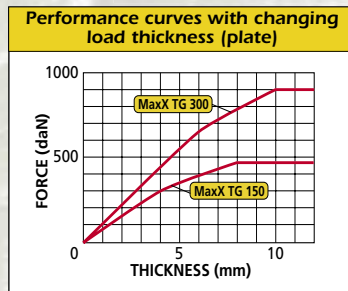
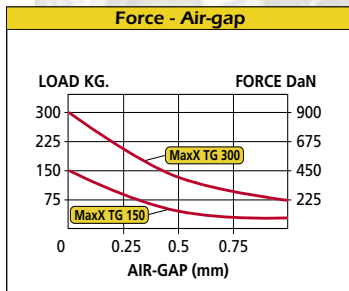

MaxX TG performance						
	Force	Load max		Thick. min	Ø max	Length. max
	kg	plate kg	round kg	mm	mm	mm
MaxX TG 150	450	150	60	8	240	1500
MaxX TG 300	900	300	120	10	290	2000

MaxX TG dimensions and weight									
	A	B	C	D	E	F	G	H	Weight
	mm	mm	mm	mm	mm	mm	mm	mm	kg
MaxX TG 150	142	130	31	79	189	170	43	35	6
MaxX TG 300	190	165	39	106	250	230	60	52	16

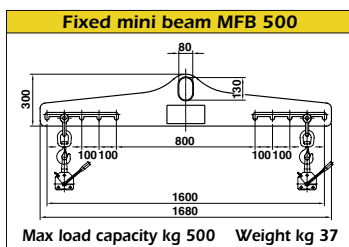

Max load capacity with MFB 500 beam					
	Sheets			Tubes	
	weight (kg)	length (mm)	width (mm)	weight (kg)	length (mm)
with 2 MaxX TG 150	200	3000	1500	100	3000
with 2 MaxX TG 300	500	3000	1500	200	3000

Head office:
TECNOMAGNETE spa
 Via Nerviano 31 - 20020 Lainate (MI) - Italy
 Tel. +39-02.937.591, Fax +39-02.935.708.57
 e-mail: info@tecnomagnete.it

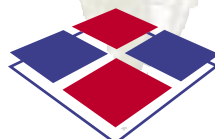

TECNOMAGNETE®
 Safety through Power
 www.tecnomagnete.com

Subsidiaries:
 France: TECNOMAGNETE S.A.R.L.
 Germany: TECNOMAGNETE GmbH
 Japan: TECNOMAGNETE Ltd
 Sweden: TECNOMAGNETE AB
 P.R. China: TECNOMAGNETE R.O.
 USA: TECNOMAGNETE Inc.

Distributor